



**OXFORD JOURNALS**  
OXFORD UNIVERSITY PRESS

**Society for Music Theory**

---

Mosaic Polyphony: Formal Balance, Imbalance, and Phrase Formation in the Prelude of Schoenberg's Suite, Op. 25

Author(s): Richard B. Kurth

Source: *Music Theory Spectrum*, Vol. 14, No. 2 (Autumn, 1992), pp. 188-208

Published by: on behalf of the [Society for Music Theory](#)

Stable URL: <http://www.jstor.org/stable/746107>

Accessed: 17/02/2014 21:30

---

Your use of the JSTOR archive indicates your acceptance of the Terms & Conditions of Use, available at <http://www.jstor.org/page/info/about/policies/terms.jsp>

JSTOR is a not-for-profit service that helps scholars, researchers, and students discover, use, and build upon a wide range of content in a trusted digital archive. We use information technology and tools to increase productivity and facilitate new forms of scholarship. For more information about JSTOR, please contact support@jstor.org.



Oxford University Press and Society for Music Theory are collaborating with JSTOR to digitize, preserve and extend access to *Music Theory Spectrum*.

<http://www.jstor.org>

# Mosaic Polyphony: Formal Balance, Imbalance, and Phrase Formation in the Prelude of Schoenberg's Suite, Op. 25

Richard B. Kurth

This essay develops a technique of phrase analysis using the pioneering work on mosaics by Donald Martino, and especially the more recent work in this area by Andrew Mead.<sup>1</sup> This analytic method takes as its starting point a pertinent mosaic on row-forms employed in a passage. The *mosaic polyphony* is constituted by the specific settings (rhythmic, registral, instrumental, and so forth) for the row-elements or segments which make up the mosaic. When Schoenberg's twelve-tone music is explored using this tool, features emerge that clarify and characterize the formation and cohesion of phrases as formal musical units.<sup>2</sup> In general,

<sup>1</sup>The term *mosaic* was introduced by Martino in "The Source Set and Its Aggregate Formations," *Journal of Music Theory* 5 (1961): 224–73. More recently it has been the subject of rigorous definition and exploration by Mead in "Some Implications of the Pitch Class/Order Number Isomorphism Inherent in the Twelve-Tone System: Part One," *Perspectives of New Music* 26, no. 2 (1988): 96–163. My work in this essay also fits well with the recent study of Schoenberg's Piano Concerto in Mead's "Twelve-Tone Organizational Strategies: An Analytic Sampler," *Intégral* 3 (1989): 93–169.

<sup>2</sup>Throughout this essay the term *phrase* will refer to a distinct section, usually of several bars in length, in the music's large-scale form. The term is never used in other senses, such as those suggested by "phrasing," or

the method shall be employed here with a view to observing factors which contribute formal *balance* to the music, and factors which contribute formal *imbalance*.

This essay will be mainly analytic in cast, and the notions of formal balance and imbalance will emerge from a number of specific analyses. The principal focus will be on the method of analysis, and the kinds of features it reveals in Schoenberg's music. Three excerpts will be examined, all drawn from the Prelude to the Suite for Piano, Op. 25, one of Schoenberg's earliest twelve-tone works. Although space limitations will not allow a close reading of the entire movement, the excerpts have been chosen for their intrinsic interest, and each plays a significant role in the overall form of the movement. Moreover, each passage illustrates a different kind of phrase formation and balance. Although the focus here is on only one piece, the method has proved to be very fruitful for other twelve-tone works by Schoenberg. In general, the stance toward the theory of phrase formation adopted here

---

"phrasing slur." The adjective *formal* will always refer to features that characterize the formation or construction of phrases or other "formal" units and subunits in the music.

will be somewhat informal, in deference to the music and its features. The author treats mosaic polyphony and phrase formation more formally elsewhere.<sup>3</sup>

Example 1 shows the first three measures of the Prelude. First, some general features of the excerpt should be noted, with particular attention to factors which establish the passage as a formal unit in the musical discourse. The excerpt employs two row-forms, P0 and P6, which are provided for reference beneath the music. The two hands occupy distinct registers; the right hand states P0, while the left hand states P6. Throughout Op. 25 Schoenberg conceives the row as a combination of tetrachords. In the example the consecutive tetrachords of each row are circled and labeled “t1,” “t2,” and “t3” respectively.<sup>4</sup> Rhythm, dynamics, and articulation help support this partition. In P0 the tetrachords are sounded successively. But in P6, t2 and t3 commence together, and t3 even finishes before t2, undermining and obscuring the interval and contour canon initially suggested between the

Example 1. Suite for Piano, Op. 25, Prelude, mm. 1–3

RH = P0

Rasch (♩. = 80)

LH = P6

P0: E F G D♭ | G♭ E♭ A♭ D | B C A B♭  
 P6: B♭ C♭ D♭ G | C A D A♭ | F G♭ E♭ E

<sup>3</sup>The author’s dissertation (in progress) includes work which deals more formally with mosaics and mosaic polyphony, and also studies in more depth the issues of phrase formation raised in this essay. The dissertation includes detailed analyses of passages from *Moses und Aron*, the Fourth Quartet, Op. 37, and the String Trio, Op. 45, to demonstrate the broader applicability of the method.

<sup>4</sup>Schoenberg’s sketches for the Suite, Op. 25 reveal that the row is not necessarily conceived as a strict linear ordering, but rather as an aggregate formed of three ordered tetrachords. A diplomatic transcription of these sketches can be found in Arnold Schoenberg, *Sämtliche Werke: Kritischer Bericht*, ed. Reinhold Brinkmann, II/B/4 (Mainz: Schott, 1975), 68–77. Ethan Haimo also provides a clear exposition of this issue in *Schoenberg’s Serial Odyssey* (Oxford: Clarendon, 1990), 84–87. Martha M. Hyde studies this passage with a view to its “secondary harmonic dimension”—the deployment of harmonies derived from set-types that are segments of the row—in “Musical Form and the Development of Schoenberg’s Twelve-Tone Method,” *Journal of Music Theory* 29 (1985): 85–143. (Pp. 120–21 examine the opening of the Prelude; extracts from other movements are also considered in the preceding and following pages.)

two rows and hands. Furthermore, P6 ends *before* P0, and B♭3, the last pitch in P0, completes both that row and the double aggregate, declaring itself with a *fortepiano*. This B♭3 also begins a new formal phrase unit—built on I6, then RP6, and characterized by running sixteenth notes—so the *fortepiano* demarcates the formal boundary between two phrase-units, mm. 1–3½, and mm. 3½–5½ which follow.

Several other relationships involving this B♭3 strengthen its role as a formal marker. In m. 3 the upbeat-to-arrival gesture <C4,A3,B♭3> underscores a special formal echo, because the <C4,A3,B♭3> rhythm reprises the opening rhythm <E5,F5,B♭3> between the hands in m. 1.<sup>5</sup> Schoenberg’s “circumflex” articulation over <C4,A3,B♭3> in m.

<sup>5</sup>Throughout this paper, *ordered* sets will be written in angle brackets, *unordered* sets in curly brackets. Registral designation of pitches is in accordance with the system used by the Acoustical Society of America; middle C is notated by “C4,” the B immediately below it by “B3,” and so forth.

3 reinforces the upbeat character of  $\langle C4, A3 \rangle$ , as a heightened echo of the opening staccato  $\langle E5, F5 \rangle$ .<sup>6</sup> Moreover, the concluding  $B\flat 3$ s of m. 3 revitalize the  $B\flat 3$  in m. 1 which begins P6. This creates a special kind of registral and tonal closure for the entire formal unit—one analogous to closing an imitative phrase on the dominant, as “tone of imitation,” rather than on the tonic. Even the change of hands during the six  $B\flat$ s of m. 3 makes a subtle echo of the  $\langle$ dotted eighth, dotted eighth $\rangle$  rhythm that opens P6 with  $\langle B\flat 3, C\flat 4 \rangle$ .<sup>7</sup> These preliminary observations already suggest notions which are essential to the characterization, cohesion, and closure of the excerpt as a formal unit in the discourse.

More interesting still are the prominent repetitions of certain pitch-class dyads. Most directly audible are the following:  $\langle G4, D\flat 5 \rangle$  in m. 1 is immediately echoed by  $\langle D\flat 3, G3 \rangle$  in m. 2;  $\langle A\flat 4, D4 \rangle$  in m. 2 is echoed by  $\langle D3, G\sharp 2 \rangle$  in m. 3;  $\langle C3, A2 \rangle$  in m. 2 is followed by  $\langle C4, A3 \rangle$  in m. 3; less obvious perhaps,  $\langle G\flat 4, E\flat 4 \rangle$  in m. 2 is reinforced by  $\langle F\sharp 2, E\flat 2 \rangle$  across the barline of m. 3. In particular, the  $\{G, D\flat\}$  repetition helps establish the written meter and dotted-quarter pulse right at the outset. Immediately following, the two  $\{C, A\}$  dyads are both aligned analogously within that dotted-quarter pulse.<sup>8</sup> Let us examine all these dyads more rigorously within the serial context, to assess their role

<sup>6</sup>Regarding Schoenberg’s articulation, see the prefatory remarks to the Belmont edition, or to the *Gesamtausgabe*, II/A/4, p. 43.

<sup>7</sup>Although the following measures are not shown on the example, this dotted-eighth rhythm is repeatedly reinforced during the stream of sixteenth notes that follow in mm.  $3\frac{1}{2}$ – $5\frac{1}{2}$ .

<sup>8</sup>The echoing dyads  $\{G, D\flat\}$ ,  $\{A\flat, D\}$ ,  $\{C, A\}$ , and  $\{G\flat, E\flat\}$  were pointed out some time ago by David Lewin in “A Theory of Segmental Association in Twelve-Tone Music,” *Perspectives of New Music* 1 (1962): 93–94. Lewin also notes here how the  $\{G, D\flat\}$  tritones—as well as the  $\{A\flat, D\}$  tritones—help establish the written meter. Ethan Haimo also considers the opening measures of the Prelude and remarks on these echoing dyads (87–88). His analysis shares some features with my own, but in general his work interprets these details in a different framework.

Figure 1. Mosaics *W1* and *M1*, on P0 and P6

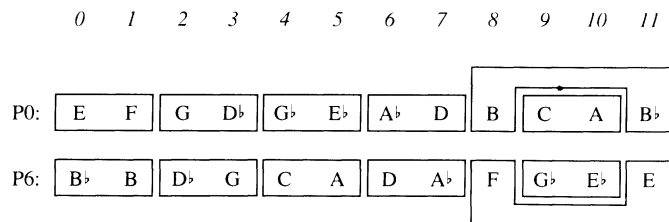

$$W1 = \{\{0,1\}, \{2,3\}, \{4,5\}, \{6,7\}, \{8,11\}, \{9,10\}\}$$

$$M1 = \{\{E,F\}, \{G,D\flat\}, \{G\flat,E\flat\}, \{A\flat,D\}, \{B\flat,B\}, \{C,A\}\}$$

$$\text{SETLIST}(M1) = (01)^2(03)^2(06)^2$$

in the formal cohesion of the excerpt, and to explore further aspects of their rhythmic deployment.

To lend precision to observations of this sort, Figure 1 articulates a dyadic *mosaic* on the two rows. The mosaic is induced by the features already noted; it delineates the dyads just identified, and adds two remaining dyads to summarize and clarify particular relationships between these rows. On each row, the *order-number mosaic* *W1*, with order-number dyads  $\{\{0,1\}, \{2,3\}, \{4,5\}, \{6,7\}, \{8,11\}, \{9,10\}\}$ , is equivalent to the *pitch-class mosaic* *M1*, with pitch-class dyads  $\{\{E,F\}, \{G,D\flat\}, \{G\flat,E\flat\}, \{A\flat,D\}, \{B\flat,B\}, \{C,A\}\}$ .<sup>9</sup> In each row *W1* groups together the pitch-class dyads of *M1*, in different positions, but in a manner consistent with *W1* over both rows. Since P0 and P6 project the same pitch-class dyads in different positions and different orders, the mosaic already suggests certain rhythmic and formal implications for the music’s discourse.

<sup>9</sup>Throughout this paper, order numbers, order-number sets, and order-number mosaics will be italicized; pitch classes, their sets and mosaics will be given in roman, and pitch-class names will be used to avoid any confusion between pitch-class numbers and order numbers.

This particular formulation of mosaics is based on that of Mead.<sup>10</sup> Mead's order-number mosaic is a partition of the order-numbers 0 through 11, construed as an *operator* on rows. (Since the mosaic is a set of sets, the constituent sets will henceforth be called its "membersets.") When such a mosaic  $W$  operates on a row  $S$ , it induces a pitch-class mosaic  $M$ . Vice versa, the pitch-class mosaic is also a partition, now of the pitch-classes, and can also be construed as an *operator*. Then  $M$  operates on a row  $S$  to induce the order-number mosaic  $W$ .<sup>11</sup> The relationships illustrated graphically in Figure 1 can therefore also be expressed formulaically:  $WI(P0) = WI(P6) = M1$ ; and  $M1(P0) = M1(P6) = W$ . Mead terms this relationship "collectional invariance."<sup>12</sup> The reader should be aware that the term "mosaic" has also been used in different—though related—senses elsewhere.<sup>13</sup> The present study employs Mead's terminology throughout, referring to entities like  $W$  and  $M1$  as "order-number mosaics" and "pitch-class mosaics" respectively. However, the entire complex of relationships illustrated in Figure 1 shall be called a "*mosaic-isomorphism*" between  $P0$  and  $P6$ . The mosaic-isomorphism should be understood as a relation between two conceptual "triples," each comprised of a row, an order-

number mosaic, and a pitch-class mosaic. In this connection, the notion of mosaic-isomorphism should be carefully distinguished from the order-number or pitch-class partitions themselves.<sup>14</sup> The idea of mosaic-isomorphism takes a conceptual stance slightly different from Mead's "collectional invariance." Since the focus of this essay is Schoenberg's music, the formalities of mosaic-isomorphisms shall not be discussed here at length.<sup>15</sup>

<sup>14</sup>It would be tempting to call the entire complex of relationships pictured in Figure 1 a "mosaic," because of its striking visual similarity to mosaic tile-work. The term "mosaic-isomorphism" retains the tile-work metaphor, without displacing the term "mosaic" as already defined by Mead and others.

<sup>15</sup>In the author's dissertation, entities like  $W$  and  $M1$  are formalized slightly differently from Mead, to stress the transformational and isomorphic aspect induced by the twelve-tone operation. This stance can be briefly summarized as follows. A row,  $S$ , is formally defined as a map from order-numbers to pitch-classes. An *order-number partition*,  $\Omega$ , and a *pitch-class partition*,  $\pi$ , are defined analogously to Mead's "order-number mosaic" and "pitch-class mosaic" respectively, but are conceived only as partitions, not as operators. When a given  $S$ ,  $\Omega$ , and  $\pi$  satisfy the equation  $S(\Omega) = \pi$ , the ordered triple  $(S, \Omega, \pi)$  is said to form a "mosaic-triple." If two rows,  $S1$  and  $S2$ , form mosaic-triples  $(S1, \Omega, \pi)$  and  $(S2, \Omega, \pi)$  for the same  $\Omega$  and  $\pi$ ,  $S1$  and  $S2$  are said to be " $(\Omega, \pi)$  mosaic-isomorphic." When  $K$  is the twelve-tone operation such that  $S2 = K(S1)$ ,  $K$  is said to be a "mosaic-isomorphism from  $(S1, \Omega, \pi)$  to  $(S2, \Omega, \pi)$ ." The labels in Figure 1 could be changed, replacing the operator  $W$  with the order-number partition  $\Omega1$ , and the operator  $M1$  with the pitch-class partition  $\pi1$ , to state that  $P0$  and  $P6$  are  $(\Omega1, \pi1)$  mosaic-isomorphic.  $T6$  is therefore the pertinent mosaic-isomorphism here. This stance stresses how the twelve-tone transformation can carry along with it the additional structures induced by  $\Omega1$  and  $\pi1$ .

The mosaic-isomorphic properties are in fact dependent only on the transformational invariance properties of the pitch-class partition  $\pi$ . The mosaic-isomorphism in Figure 1 results from the fact that  $\pi1 = \{\{E, F\}, \{G, D\}, \{G\flat, E\flat\}, \{A\flat, D\}, \{B\flat, B\}, \{C, A\}\}$  maps to itself under  $T6$ ; that is,  $T6(\pi1) = \pi1$ . Let  $J$  be the twelve-tone inversion that exchanges  $E$  with  $F$ ,  $E\flat$  with  $F\sharp$ , and so forth. Readers may confirm for themselves that  $J(\pi1) = \pi1$  as well. Let  $I1$  be the inversional form of the row from the Suite which begins on  $F$ ; that is,  $I1 = J(P0)$ . Readers may then confirm that  $P0$  and  $I1$  are also  $(\Omega1, \pi1)$  mosaic-isomorphic.  $I1$ , however, is a form of the row which is not directly employed in the Suite.

<sup>10</sup>I follow Mead, "Some Implications," 103–5, with but a few slight changes in labeling and typography. I use italic  $W$ -labels for order-number mosaics, and roman  $M$ -labels for pitch-class mosaics. (Mead uses bold  $W$ -labels for order-number mosaics, and italic  $W$ -labels for pitch-class mosaics.)

<sup>11</sup>The visual "inversion" of the letters  $W$  and  $M$  is used here to suggest their quasi-inversional relationship, informally speaking, as *operators* on a row  $S$ .

<sup>12</sup>Mead develops this idea in considerable theoretic detail in "Some Implications," 106–12.

<sup>13</sup>In particular, Robert D. Morris and Brian Alegant define their "partition" analogously to Mead's "mosaic," and then define their "mosaic" as a set of partitions that are equivalent under transposition and/or inversion. Their "mosaic" is equivalent to Mead's "mosaic-class." See their "The Even Partitions in Twelve-Tone Music," *Music Theory Spectrum* 10 (1988): 74–101.

It will be useful to characterize pitch-class mosaics on the basis of their harmonic set-type content, and to compare different pitch-class mosaics in this manner as well. The function SETLIST performs this role; at the bottom of Figure 1 SETLIST collates the harmonic content of M1, listing its constituent set-types in the standard “exponential” notation. Since M1 has two semitone dyads, two 03 dyads, and two tritone dyads,  $\text{SETLIST}(M1) = (01)^2(03)^2(06)^2$ . This harmonic content gives the mosaic a specific aural profile. The SETLIST function may be used on any pitch-class mosaic, regardless of the size and number of its membersets. In general, the more clearly the mosaic is articulated in the music, the more accurately will SETLIST model the aural surface.<sup>16</sup>

---

Some readers may have already noted that the mosaic-isomorphism of Figure 1 represents a special case of “isomorphic partitioning,” an idea discussed in detail by Ethan Haimo and Paul Johnson in “Isomorphic Partitioning and Schoenberg’s Fourth String Quartet.” *Journal of Music Theory* 28 (1984): 47–72. Under the mosaic-isomorphism, not only are P0 and P6 partitioned “isomorphically” by  $\Omega 1$ , but that partition induces the *same* pitch-class sets on both rows, the sets that comprise  $\pi 1$ .

<sup>16</sup>It is also important to develop a measure of the order-number mosaic’s abstract rhythmic and order implications within the row. Although it will not be invoked in the following analyses, the Disjunction Index function, or DI, provides one such measure. For each order-number dyad  $\{n, n + 1\}$ , as  $n$  ranges from 0 to 10, the DI counts the number of such dyads that *do not belong to the same memberset* of the order-number mosaic. For instance, for  $W1$  in Figure 1,  $\text{DI}(W1) = 6$ , since the order-dyads  $\{1, 2\}$ ,  $\{3, 4\}$ ,  $\{5, 6\}$ ,  $\{7, 8\}$ ,  $\{8, 9\}$ , and  $\{10, 11\}$  all straddle the boundaries of membersets in  $W1$ . Like SETLIST, the DI value may be ascertained for any order-number mosaic, regardless of the number or size of its membersets. Because of this generality, the DI alone will not always yield a very sophisticated comparison of different order-number mosaics; in fact, many very different mosaics will share the same DI value (ranging from a minimum of 0, to a maximum of 11). There are a number of ways in which the DI may be scaled and adjusted to compare order-number mosaics with the same or different number of membersets. But on a more immediate level, the DI reflects quite well how the order-number mosaic induces a specific segmentation of the aggregate, against the context of the linear ordering of the row. Put more simply still, the DI measures the serial segmentation induced by the order-number mosaic. In tandem with the

More fundamentally, Figure 1 indicates that the dyads first observed analytically in the music are also girdled by a special relationship between rows, order-number mosaics, and pitch-class mosaics. This mosaic-isomorphism itself shows how the two rows collectively support the six pitch-class dyads of M1 as pertinent formal or rhetorical subunits, rigorously conceived within the twelve-tone context. It is important to stress here that because a very large number of pitch-class partitions are T6-invariant, many other mosaic-isomorphisms can be found between P0 and P6. So it is crucial to note that the mosaic-isomorphism of Figure 1 arises first from dyads observed analytically; and those dyads have the special property that they *induce* a mosaic-isomorphism. Throughout this essay care will be taken to induce mosaic-isomorphisms in this way—from analytic observations; however, to speed the flow of the argument, the mosaic-isomorphisms will often be shown first, and their analytic support detailed after.

Because the M1 membersets (dyads) can be conceived as formal or rhetorical subunits, and because of their abstracted or revised “serial” parsing under  $W1$ , their rhythmic relationships will be of interest. The form-producing aspect of these rhythmic relationships between subunits must be conceived as analytically twofold. It must be considered on the one hand with regard to specific *quantitative* relations between durations and metric alignments and, on the other, with regard to more abstract *qualitative* relations—that is, allowing for the fact that one subunit may precede, follow, or overlap another in temporal progression.

To explore how the abstract implications of the mosaic-isomorphism in Figure 1 are projected in the music, Example 2 depicts the *mosaic polyphony* of the excerpt, by collating the music of Example 1 according to mosaic M1. Each staff corresponds to the rhythmic surface that presents, and is pre-

---

visual layout of the order-number mosaic, the DI also suggests some of the abstract rhythmic implications of the mosaic.

Example 2. *Mosaic-rhythm* of M1 in mm. 1–3

sented by, one of the pitch-class dyads in the mosaic. This method promotes analysis of rhythmic aspects—both qualitative and quantitative—which determine or affect the formal properties of each individual dyad-stratum. The method also renders more obvious the registral presentation of dyads. The example pairs staves with equivalent interval-class content to highlight specific features.

Because mosaics *W1* and *M1* associate dyads between two rows, each pitch-class dyad sounds as antecedent in one row and is repeated as consequent in the other; sometimes the consequent dyad retrogrades the ordering of the antecedent.

So each individual stratum (staff) displays a miniature antecedent-consequent construction, with highly individualized rhythmic and registral features that sculpt its formal and gestural shape.

The strata of Example 2 will now be examined individually and in pairs to explore their form-producing features. The guiding concern will be: “What factors contribute cohesion and formal balance (or imbalance) to individual or paired strata, and how do these factors interact when the passage is heard as a whole?” In the rest of this section, “antecedent-consequent” will refer to structures in a single individual dyad stratum, while the special locution “ANTecedent-CONsequent” will refer to more complex and developed structures among *two or more* dyad strata in combination.

The tritones  $\{G, D\flat\}$  and  $\{A\flat, D\}$  are found on the two lowest strata of Example 2; the symbol “06” at the lower left of the example indicates the basis for pairing the two tritones. We have already observed how the  $\{G, D\flat\}$  tritones help establish the written meter; in the  $\{A\flat, D\}$  stratum, the consistent arrival of Ds on dotted-quarter pulses also reinforces the meter and continues to associate those pulses with tritones. The format of Example 2 suggests parsing together the two  $\{G, D\flat\}$  dyads, both with rising contour, followed by the two  $\{A\flat, D\}$  dyads, parsed together, both with descending contour. This description carries the abstract formal balance: “ $\{G, D\flat\}$  twice ascending (ANTecedent), then  $\{A\flat, D\}$  twice descending (CONsequent).” This observation mostly reflects *qualitative* rhythm, for the quantitative rhythms of this formal balance are somewhat deformed—or at least subject to extreme variation—even though each gesture articulates a successive dotted-quarter pulse. However, the formal balance is supported by registral deployment: the ANTecedent, registally ordered  $\{D\flat 3, G3, G4, D\flat 5\}$ , and the CONsequent, registally ordered  $\{G\sharp 2, D3, D4, A\flat 4\}$ , form identical intervallic structures. They invert as well into one another about the pitch dyad  $\{B\flat 3, C\flat 4\}$ —precisely the two pitches deployed to open P6.

Some other higher-level ANTEcedent-CONsequent structures can also be heard between these two strata. Another hearing is suggested by the notation of Example 3a, which uses the criterion of registral proximity to pair dyads on each staff. On the ANTEcedent treble staff,  $\langle G4, D\flat 5 \rangle$  is answered by  $\langle A\flat 4, D4 \rangle$ ; and on the CONsequent bass staff,  $\langle D\flat 3, G3 \rangle$  is answered by  $\langle D3, G\sharp 2 \rangle$ . Overall, one hears a hocketed canon at the tritone, exact in contour and interval, but free in rhythm. Here the formal balance is one of alternation. Again, both staves build identical intervallic structures which are each symmetric (shown at the right). And again, the ANTEcedent and CONsequent tetrachords invert into one another about the pitch dyad  $\{B\flat 3, C\flat 4\}$ .

Example 3b offers yet another possible parsing, one which underscores a *quantitative* rhythm relationship. The example pairs the initial  $\langle G4, D\flat 5 \rangle$  with the final  $\langle D3, G\sharp 2 \rangle$ ; both gestures share the same attack rhythm, aligned identically within the half-measure pulse. Each gesture occupies one registral extreme. As an unordered registral set,  $\{G\sharp 2, D3, G4, D\flat 5\}$  is independently symmetric about  $\{B\flat 3, C\flat 4\}$ . The entire unit links the beginning and end of the excerpt, with some registral focus about  $B\flat 3$  (and  $C\flat 4$ ), giving direct support to earlier preliminary observations of closure about  $B\flat 3$ . The two temporally “interior” gestures,  $\langle D\flat 3, G3 \rangle$  and  $\langle A\flat 4, D4 \rangle$ , are also paired. Comprising an unordered registral set,  $\{D\flat 3, G3, D4, A\flat 4\}$ , they are also registally “interior,” and they too are symmetric about  $\{B\flat 3, C\flat 4\}$ .

Each of these three hearings of the two tritone strata suggests a different ANTEcedent-CONsequent formation: the first is “before-then-after,” the second “alternating,” and the third “enveloping.” Each establishes registral symmetry about  $\{B\flat 3, C\flat 4\}$  in a different way; and each sets its ANTEcedent and CONsequent in a different way against the four successive dotted-quarter pulses. The first two readings give greatest stress to the registral opposition of ANTEcedent and

Example 3a. Alternative  $\{G, D\flat\} \{A\flat, D\}$  interpretation

Example 3b. Second alternative  $\{G, D\flat\} \{A\flat, D\}$  interpretation

CONsequent; neither stratum itself is symmetric about  $\{B\flat 3, C\flat 4\}$ , but collectively the two strata are. In Example 3b, on the other hand, ANTEcedent and CONsequent are each independently symmetric about  $\{B\flat 3, C\flat 4\}$ , and the *quantitative* rhythmic relationship between the first and last gestures is stressed. These three readings all depend on the same features, so they are not mutually exclusive; rather, they indicate three facets of the formal balance established by  $\{G, D\flat\}$  and  $\{A\flat, D\}$  strata in tandem. This striking formal and registral balance is articulated against a more fluid rhythmic structure, which is relatively imbalanced but nonetheless supports a regular dotted-quarter pulse. The sophisticated discourse between formal balance and imbalance begins to indicate an important aspect of the phrase as a whole.

In the middle two strata on Example 2 (those marked “03” at the left of the example), both  $\langle G\flat, E\flat \rangle$  and  $\langle C, A \rangle$ , as ordered dyads, are repeated. In this respect, they are unlike



the four remaining strata, all of which retrograde the second statement of their dyads. The repetition of ordered dyads characterizes the echo in these two strata, and may strengthen the echo's formal effect for some listeners. Compared to the antecedent  $\langle G\flat 4, E\flat 4 \rangle$ , the consequent  $\langle F\sharp 2, E\flat 2 \rangle$  dyad is heard in lower register, lower dynamic, and with *attenuated* articulation. Both  $\langle G\flat, E\flat \rangle$  dyads have the same attack rhythm, with varied metric deployment; this introduces a quantitative rhythmic relationship. On the other hand, the consequent  $\langle C4, A3 \rangle$  dyad sounds an octave higher than its antecedent, with *heightened* articulation. The quantitative rhythmic relation between the  $\langle C, A \rangle$  dyads is very strong; both have the same attack rhythm and analogous metric alignment within the half-measure pulse. The two 03 strata therefore have opposed or complementary features of contour, articulation, and register. As in Example 3a, they establish a combined formal balance which—in qualitative rhythm—is temporally “alternating,” much as in Example 3a.

Example 4 offers another way to hear a formal balance between these two 03 strata. The example uses row-membership and registral proximity as criteria for its parsing. The ANTEcedent upper staff is derived entirely from P0; it establishes a “close-position” 0369 set as a long-range linear gestalt. The lower staff, all derived from P6, builds another linear 0369 gestalt, this one temporally “interior” and truncated (overlapped). The resulting abstract balance is temporally “enveloped”—in qualitative rhythm—as in Example 3b, but the ANTEcedent and CONsequent are registally independent, as in Example 3a. Again, our parsings of the two 03 strata suggest certain kinds of formal balance, against a backdrop of imbalance or irregularity in some parameters.

The  $\{E, F\}$  stratum at the top of Example 2 counterposes the registral and relative temporal extremes of the passage. The consequent dyad retrogrades the antecedent, and their inverted contours cast a striking balance in the exterior registers. The entire  $\{E, F\}$  stratum is also registally symmetric

Example 4. Alternative  $\{G\flat, E\flat\} \{C, A\}$  interpretation

The musical score for Example 4 consists of two staves, treble and bass clef, in 3/8 time. The upper staff (treble clef) is labeled 'P0' and contains three measures. Measure 1 has a quarter note G4 and a quarter note E4. Measure 2 has a quarter note F#2 and a quarter note E2. Measure 3 has a quarter note C4 and a quarter note A3. The lower staff (bass clef) is labeled 'P6' and contains three measures. Measure 1 has a quarter note G3 and a quarter note E3. Measure 2 has a quarter note F2 and a quarter note E2. Measure 3 has a quarter note C2 and a quarter note A2. Dynamic markings 'p' and 'pp' are placed below the lower staff. Articulation marks (^) are placed above the notes in measure 3 of both staves.

about the  $\{B\flat 3, C\flat 4\}$  dyad, and that pitch-inversional symmetry complements the pitch-class palindrome  $\langle E, F, F, E \rangle$ . Furthermore, the attack-points of pitch-classes E and B $\flat$  are identical in mm. 1 and 3. This rhythmic parallelism supports the exact pitch symmetry of the opening E5 and closing E2 about B $\flat$ 3. It also reflects the symmetric *serial* relationship of pitch-classes E and B $\flat$ —as the first and last members of both rows—and further strengthens the powerful rhetorical effect of closing on B $\flat$ 3.

In the  $\{B\flat, B\}$  stratum, unlike all the others, the two pitch-class dyads do not have the same pitch size:  $\langle B\flat 3, C\flat 4 \rangle$  in m. 1 spans a single semitone, while  $\langle B4, B\flat 3 \rangle$  in mm. 2–3 spans 13 semitones. This produces more registral *imbalance* than any other stratum. Even while B $\flat$  is fixed at B $\flat$ 3—a feature already engaged in a variety of formal balances—and even while the opening dyad  $\langle B\flat 3, C\flat 4 \rangle$  is an axis for several observed symmetries, the second B, placed at B4, defies this pattern. As it does so, it asserts itself with a *sforzando*. This marking should be taken as an important clue—for the analyst and the performer—since it underscores a special imbalance in a context dominated by other individual or paired symmetries.<sup>17</sup>

This commentary on Example 2 has indicated a number of salient features revealed by an analysis of the mosaic

<sup>17</sup>The *sforzando* B4 also draws the listener to the retrograde BACH tetra-chord embedded in P0.

polyphony. Various repetitions, rhythmic relationships, symmetries, and ANtecedent-CONsequent models are heard among the individual and combined strata. These generate several qualities of formal “balance,” often operating in the same strata, but developed through different combinations of parameters—register, qualitative or quantitative rhythm, and overall formal layout. The individual or paired strata contribute to the sense of formal balance and cohesion of the entire excerpt. When heard together, all six strata combine to create a complex shifting state, intermingling conditions of balance and imbalance, which gives the music a varied, fluid shape and dynamic character. The various balances are actually conveyed through a rhythmic surface which is less symmetrical and regular, and, so to speak, more “imbalanced.” Mosaic polyphony provides a concise, detailed picture of Schoenberg’s formal rhetoric and use of “developing variation” across several *combined* parameters, and does so in a rigorous twelve-tone context.

\* \* \*

Figure 2 shows a new mosaic-isomorphism related to another passage from the Prelude. Its order-number mosaic  $W2$  has dyads  $\{\{0,1\}, \{2,3\}, \{4,6\}, \{5,7\}, \{8,9\}, \{10,11\}\}$ . Applied on the inversionsal rows P0 and I6, it induces the same pitch-class mosaic  $M2 = \{\{E,F\}, \{G,D^b\}, \{G^b,A^b\}, \{E^b,D\}, \{B,C\}, \{A,B^b\}\}$ .  $W2$  will induce an analogous pitch-class mosaic on any pair of rows  $P_x$  and  $I_{x+6}$ .  $SETLIST(M2) = (01)^4(02)(06)$ , so  $M2$  is mainly characterized by semitones.  $SETLIST(M2)$  thus suggests a shift in aural content from the opening measures, where  $SETLIST(M1) = (01)^2(03)^2(06)^2$ . Example 5 shows the passage from which mosaic  $W2$  has been deduced. Observations here will focus on mm. 15–16; m. 14 is provided to give some context for the passage.

Three gestures are used in mm. 15–16 to set rows P0 and I6. Each gesture articulates an inversionally related pair of

Figure 2. Mosaics  $W2$  and  $M2$ , on P0 and I6

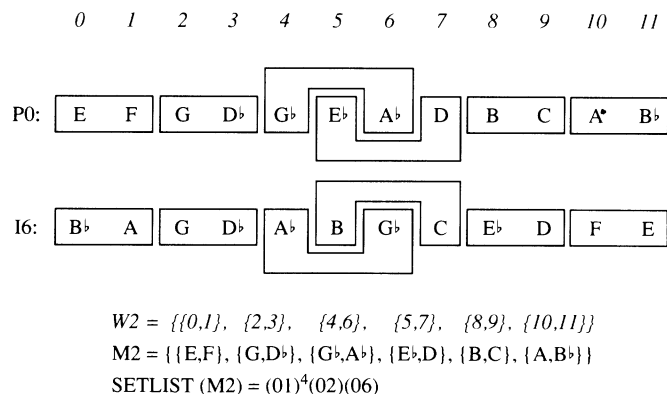

tetrachords from the row-pair, and each gesture is isolated by a fermata. The passage has a cadential function and a formal one: it closes a long *ritardando*, and is followed a *tempo* by a varied recapitulation of the opening measures. Order-number indications in Example 5 can be compared with the rows and mosaic in Figure 2. For instance, the first half of m. 15 sets the first tetrachord of each row. On the downbeat, the left-hand  $\{G,D^b\}$  simultaneously expresses order-positions  $\{2,3\}$  from both P0 and I6; the right hand first plays  $\{0,1\}$  from P0, then  $\{0,1\}$  from I6. The second tetrachords are deployed similarly. The left-hand  $\{G^b,A^b\}$  simultaneously articulates  $\{4,6\}$  in both P0 and I6; the right hand has  $\{5,7\}$  from P0, then  $\{5,7\}$  from I6. So far, the right-hand P0 dyads are all in metrically strong positions, and the matching I6 dyads metrically weak, but *with fermatas*. Even against the *ritardando*, these distinctions are easily perceived; P0 dyads begin each audibly separate gesture, and I6 dyads close each gesture, followed by a rest. The right-hand P0 and I6 dyads are clearly and formally distinguished in this manner, even though all four dyads have interval-class 1. The treatment of the third tetrachords, in m. 16, varies the established

## Example 5. Prelude, mm. 15–16

Annotations above the staff:

- 14: *etwas langsamer*
- 15: *rit.*
- 16: *tempo*
- P0: I6: /0, 1/ /0, 1/
- P0: I6: /5, 7/ /5, 7/
- I6: /8, 9/
- {E♭, D}

Annotations below the staff:

- P0/I6: /2, 3/
- P0/I6: /4, 6/
- P0: /8, 9, 10, 11/ /10, 11/
- I6: /F, E/
- t1
- t2
- t3

pattern. Now the rows are distinguished by *sustained* versus *moving* parts. The entire third tetrachord of P0—reading from the bottom up, A2, C3, C♭4, and B♭4—is struck on the downbeat of m. 16 and is sustained. (In m. 15, by contrast, it was members of I6 which were sustained, under fermatas.) The appropriate mosaic *dyads* in m. 16 belong to I6. Two dyadic motions are clearly heard; in the right hand E♭4 moves to D4, and in the left F3 moves to E3. These motions are distinguished by register and rhythm, and they articulate {8,9} and {10,11} as the appropriate mosaic dyads in I6, and in P0 by analogy.

Taken together, Figure 2 and Example 5 illustrate how closely the mosaic-isomorphism corresponds with the design of the passage. They also stimulate observations about formal balance in the passage. The right-hand P0 dyads in m. 15, {F,E} and {E♭,D}, are simultaneities occurring on the beat. But they are precisely the pitch-class dyads which are mobile and metrically free in m. 16, where they derive in turn from I6. Complementarily, the right-hand I6 dyads in m. 15, con-

sistently off-beat, sound on the downbeat in m. 16, where they derive as {8,9,10,11} from P0. These features develop a formal balance between mm. 15 and 16, answering the first two gestures with the third one.

The voice leading also affects the passage's formal properties. The right hand builds two symmetric wedges: a "soprano" wedge, <E5,A4,D5,B4>, and a parallel "alto" wedge, <F4,B♭3,E♭4,C4>, consistently eleven semitones below the soprano. The "rhetorical" expectations that might be generated by this structure—such as a further symmetric "gap-filling"—are not carried through consistently in the right-hand registers of the next measure. Instead, continuity is more directly secured between mm. 15 and 16 by the linear and more consistent voice leading of the left hand: by the linear chromatic descent <G3,G♭3,F3,E3> in the tenor; and by the symmetric bass wedge <D♭3,A♭2,C3/A2>. The tenor and bass structures both require all three gestures in order to form gestalts, and so they bind those three gestures together. But in m. 15 the left hand does not suggest



This citation certainly seems to apply to the excerpt at hand. Coherent harmony is established by consistent semitone dyads, first heard as simultaneities in the right hand of m. 15. (It is useful to remember here that  $\text{SETLIST}(M2) = (01)^4(02)(06)$ , so  $M2$  is quite dominated by semitones.) Rhythmic, metric, and gestural correspondences draw together the respective  $P0$  and  $I6$  semitones of m. 15 into chromatic tetrachords. These are motive-forms derived from the BACH tetrachord basic to the row. The tenor tetrachord, another BACH-derived motive-form, is also built from two consecutive semitone motives. The common content and coherent harmony (simultaneous or consecutive semitones), as well as the continuous tenor voice leading, guarantee that Schoenberg's requirements for logic are fulfilled. The relationship between the right-hand wedges and the bass wedge can be glossed similarly. Here dyads of interval-class 5 (soprano  $\langle E5, A4 \rangle$ , alto  $\langle F4, B\flat3 \rangle$ ) and interval-class 3 (soprano  $\langle D5, B4 \rangle$ , alto  $\langle E\flat4, C4 \rangle$ ) provide the common content, and coherent harmony. These reappear in the bass:  $\langle D\flat3, A\flat3 \rangle$  belongs to interval-class 5, and  $\langle A2/C3 \rangle$  to interval-class 3. The rhythmic expression of the bass wedge begins as though it were an augmentation of the right-hand wedges. The voice-leading wedge in the bass also appears to respond to the semitone motions that dominate the rest of the texture.

\* \* \*

Two distinct formal units in the music—the opening and the retransition to its reprise—have been examined thus far, illustrating two different kinds of formal phrase composition. In each case, the mosaic polyphony has facilitated an understanding of how various factors create the formal balance and imbalance which shape perception of the excerpt. A third passage shall now be analyzed, one chosen for its quite extreme opposition of balancing and unbalancing factors. As before, the mosaic-isomorphism at work shall be presented prior to the discussion of the music.

Figure 3. Mosaics  $W3$  and  $M3$ , on four principal rows individually

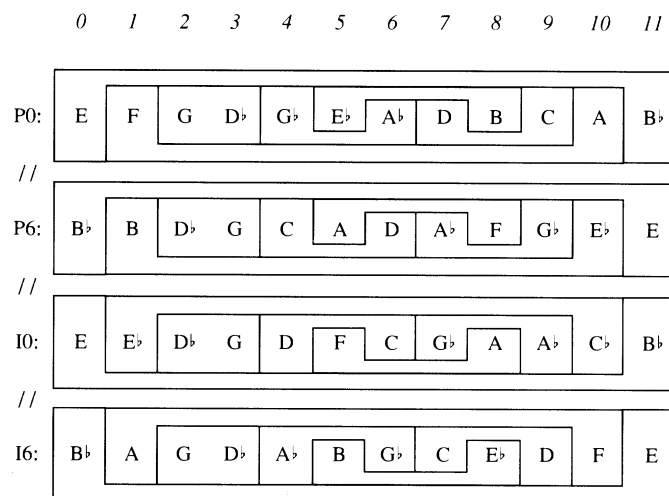

$$W3 = \{\{0,11\}, \{1,10\}, \{2,3\}, \{4,6\}, \{5,8\}, \{7,9\}\}$$

$$M3 = \{\{E, B\flat\}, \{F, A\}, \{G, D\flat\}, \{G\flat, A\flat\}, \{E\flat, B\}, \{C, D\}\}$$

$$\text{SETLIST}(M3) = (02)^2(04)^2(06)^2$$

Figure 3 illustrates the new mosaic-isomorphism. The order-number mosaic  $W3 = \{\{0,11\}, \{1,10\}, \{2,3\}, \{4,6\}, \{5,8\}, \{7,9\}\}$  actually induces the same pitch-class mosaic  $M3$  on four different rows,  $P0$ ,  $P6$ ,  $I0$ , and  $I6$ . (Along with their retrogrades, these make up the entire set of rows used in the Suite.)  $\text{SETLIST}(M3) = (02)^2(04)^2(06)^2$ , which comprises only even intervals. The visual layout of the figure illustrates that  $W3$  is even more disjunct than the preceding order-number mosaics. It will be shown shortly that the music from which it is derived is serially disjunct in other ways as well.

This mosaic-isomorphism also relates linear ordering in the row to pitch-class inversive symmetries. Every dyad in  $M3$  inverts into itself under inversion about  $G$  or  $D\flat$ . So when  $W3$  is applied on inversive rows related about that center,

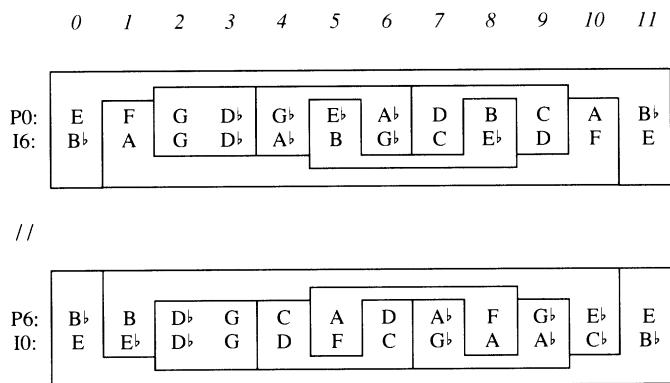
Figure 4. Mosaics  $W3$  and  $M3$ , on inversional row-pairs

$$W3 = \{\{0,11\}, \{1,10\}, \{2,3\}, \{4,6\}, \{5,8\}, \{7,9\}\}$$

$$M3 = \{\{E,B\flat\}, \{F,A\}, \{G,D\flat\}, \{G\flat,A\flat\}, \{E\flat,B\}, \{C,D\}\}$$

such as P0 and I6,  $W3$  isolates each dyad in the same order-positions of both rows, but with reversed ordering. Figure 4 shows that  $W3$ , applied on the row-pairs P0/I6 and P6/I0, consistently (or one might informally say “simultaneously”) yields pairs which share the  $G/D\flat$  inversional axis.

Example 6 provides the music at the stunning climax of the Prelude, the passage from which this mosaic-isomorphism has been deduced. This passage exploits the characteristic row-pairing of Figure 4. The following analysis focuses on mm. 17½ through 19, the climax proper; m. 16 is also given to show how the varied recapitulation leads into the climax. The commentary will provide motivation to hear mm. 17½–19 as a distinct formal unit.

Beginning in m. 17½ the inversional rows P0 and I6 are paired rigorously. Each simultaneous dyad deploys the same order number from P0 and I6. Arabic numerals over each dyad indicate its order-number derivation; numbers within

parentheses indicate simultaneous derivations. Beginning near the end of m. 18, P6/I0, the other inversional row-pair, is deployed analogously. This setting of inversional row-pairs illustrates mosaic  $W3$  as just shown in Figure 4. But the order numbers in Example 6 indicate that Schoenberg does not strictly follow the linear ordering of the rows. To show how the literal row-ordering is altered, Figure 5 collates the successive order-number entries in each row-pair. Even though the ordering is quite scrambled, beams in the example confirm that the tetrachords  $\{0,1,2,3\}$ ,  $\{4,5,6,7\}$ , and  $\{8,9,10,11\}$  are treated independently and partially ordered in each row-pair.<sup>20</sup> Figure 5 indicates that succession in the excerpt is *serially* very disjunct, in addition to the disjunction characteristic of  $W3$  itself.

This music is dense, and audibly imbalanced. What factors contribute to its formal structure and create this palpable sense of imbalance? Example 7a will help answer this question; it gives the mosaic polyphony for the passage. Following the earlier format, each staff documents the entries of one dyad in the pitch-class mosaic  $M3$ . The mosaic polyphony shows that the scrambling of the row-ordering is not haphazard; it serves to compose a network of palindromes, indicated by the trapezoidal boxes on the example. Even though the music is dense and complex, each palindrome, as a rigorous construction of pitches in time, suggests a powerful and independent formal balance. The following analysis is complicated and requires particularly careful study; its conclusions depend on a large number of observations, many of which “account for” details in the music by attributing a contextual formal function to them.

<sup>20</sup>An excellent general discussion of partial ordering is found in David Lewin, “On Partial Ordering,” *Perspectives of New Music* 14, no. 2/15, no. 1 (1976): 252–57. Many of the theoretical and compositional implications of partial ordering are explored in depth by Daniel Starr in “Derivation and Polyphony,” *Perspectives of New Music* 23, no. 1 (1984): 180–257.

## Example 6. Prelude, climax, mm. 17–19

Figure 5. Successive order entries in mm. 17–19

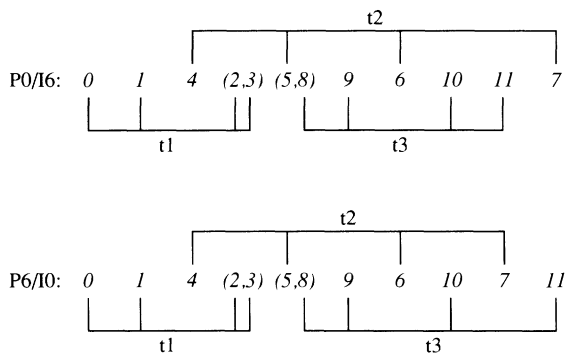

The right-most palindrome on the example, marked by the letter gamma, is the most important and immediately audible of the three. Its contour gestalt is particularly clear upon audition, and guides the ear to the palindrome. Example 7b isolates the gamma palindrome to render it more visible and

audible. Over the antecedent section of the palindrome the two hands descend *in parallel*.<sup>21</sup> The consequent section strikingly inverts that relationship; the two hands now proceed *in contrary* motion. The overt contour shift from antecedent to consequent draws attention to the retrograding pitch-class dyads. The palindrome also receives considerable rhythmic support. The gamma rhythm is extracted at the bottom of Example 7b. One sees immediately that the antecedent and consequent entries are rhythmically and metrically analogous. The temporal center of the gamma palindrome is articulated by a powerful gesture, the motion from the last sixteenth of m. 18 to the downbeat of m. 19. The downbeat is stressed by a loud and firm {G,D<sup>b</sup>}, two octaves below the analogous downbeat of m. 18 (see Ex. 7a). The last sixteenth of m. 18 is articulated by two events: a {C<sup>b</sup>,E<sup>b</sup>} attack, and a repeated {C,D} attack. The rhythm of the two {C,D} dyads

<sup>21</sup>The second right-hand dyad is not entirely below the first. But the descending motion of the highest voice, in parallel with the two left-hand voices, overrides the ascending motion in the second-highest voice.

Example 7a. *Mosaic-rhythm* of M3 in mm. 17–19 (with alpha, beta, and gamma palindromes)

The musical score consists of six staves, each representing a different pitch class: E, B $\flat$ ; F, A; G $\flat$ , A $\flat$ ; C, D; C $\flat$ , E $\flat$ ; and G, D $\flat$ . The notation includes various rhythmic values, rests, and dynamic markings such as *ff* and *sf*. The score is annotated with three palindromes:  $\alpha$  (top),  $\beta$  (bottom), and  $\gamma$  (middle). Numerical indices (0, 1, 4, 6, 7, 9, 10, 11) and groupings (2, 3, 5, 8) are placed throughout the score to indicate specific rhythmic and serial features.

immediately preceding is crucial here. It creates a striking syncopation, at the level of the predominating eighth-note pulse; the resulting rhythmic tension contributes even greater focus to its rhythmic resolution, the sixteenth-to-downbeat gesture which stresses the center of the palindrome.<sup>22</sup> The {C,D} on the last sixteenth also signals a change in serial function, from order-number 7 in P0/I6, to order-number 4

in P6/I0. This {C,D} attack is also the serial and metric analog of the {G $\flat$ ,A $\flat$ } attack at the end of m. 17, which heralds the *fortissimo* dynamic of the entire passage.<sup>23</sup> The serial analogy and the row modulation help to articulate the center of the gamma palindrome. Example 7a also shows that the gamma antecedent and consequent are not just rhythmically and metrically analogous; both are also preceded by the longest lapses

<sup>22</sup>None of the events which articulate the center of the gamma palindrome are part of the palindrome itself. But it is notable that they are prepared in the last two eighths of m. 18, immediately following the gamma antecedent, thus accounting for almost all events heard between the gamma antecedent and consequent.

<sup>23</sup>The tritone {G, D $\flat$ }, always occurring on metric downbeats in this passage, helps reinforce the serial analogy of the two order-number 4 dyads, which both occur one sixteenth before the barline. Schoenberg frequently uses {G, D $\flat$ } to articulate metric groupings in various ways throughout the Suite Op. 25.



Example 7b. Gamma palindrome isolated

Example 7c. Alpha palindrome isolated

in the attack stream, a full three sixteenths after the attack on the downbeat. All these factors support the palindrome as an important formal structure in the excerpt.

In Example 7a the alpha and beta palindromes are surrounded by dotted boxes to indicate that they are more difficult to perceive, and are in this sense subsidiary to the gamma palindrome. The alpha palindrome is quite difficult to hear at first. In part this is because its antecedent entries do not form an obvious gestalt, since the initial E4 and B $\flat$ 2 are elided from the ends of the two preceding rows (P6 and P0 respectively). The listener is guided into the alpha palindrome, however, by two forceful gestures at the end of m. 17: the tricky left-hand leap to {A3, F4}, within crescendo, followed by the *fortissimo* attack on the sustained {A $\flat$ 5, G $\flat$ 6}.

This can be seen in Example 7c, which isolates the alpha structure. The *sforzando* {G4, D $\flat$ 5} on the downbeat of m. 18 (not part of the palindrome, and parenthesized in the example) signals the end of the alpha antecedent entries. Those three entries produce a consistently ascending contour, so the return to middle register clearly distinguishes the *sforzando* from the completed alpha antecedent. Each dyad entry in the antecedent has a single attack; but in the consequent each dyad is repeated, and their entries are overlapped.<sup>24</sup> The

<sup>24</sup>Perhaps the repetition of dyads in the alpha consequent signals the fact that two of these dyads—unlike any of the antecedent ones—function both in the alpha and gamma palindromes. The other gamma antecedent dyads also have a double function, since they are shared with the beta palindrome. The

alpha rhythm is extracted directly beneath the example, and below it is shown the reduced *dyad entry-attack rhythm*. The first sixteenth in the reduced entry-attack rhythm corresponds with the moment at which {E4,B♭2} is realized as a vertical dyad. Both antecedent and consequent entry-attack patterns are three consecutive sixteenths. The first entry in the gamma palindrome, the {C♭5,E♭5} on the fourth sixteenth of m. 18, corresponds quite nicely with the approximate temporal center of the reduced alpha rhythm.<sup>25</sup> This factor apparently motivates a characteristic of the gamma rhythm noted earlier—the three-sixteenth lapse in the attack stream after the downbeat. It provides as well subtle but suggestive evidence for the alpha palindrome.

The beta palindrome is isolated in Example 7d. The antecedent is entirely ascending, the consequent descending. The reduced dyad entry-attack rhythm is again given below the music. The last attack of antecedent and consequent are written with x-noteheads, to stress their identical relations to the preceding attacks, even though they have different durations. The effect of the {C,D} syncopation in the consequent has already been noted; that rhythm is reduced to a dotted eighth in the entry-attack stream, since the syncopating attacks both express the same dyad. The reduction shows how the antecedent and consequent delineate the same rhythm: dotted eighth-then sixteenth-then final attack. This analogy supports the palindrome, and also suggests a  $\frac{3}{4}$  subdivision of the bar, against the written  $\frac{6}{8}$  meter. Several other features in the passage support a  $\frac{3}{4}$  hearing.<sup>26</sup> Metric ambiguity in-

Example 7d. Beta palindrome isolated

The musical score for Example 7d shows two staves. The upper staff is in treble clef with a key signature of one flat (B♭) and a 6/8 time signature. It contains measures 18 and 19. Measure 18 starts with a piano (*sf*) dynamic and a half-note chord. Measure 19 begins with a forte (*ff*) dynamic and contains a series of sixteenth-note attacks. The lower staff is in bass clef and provides harmonic support. Below the main score, a 'dyad entry - attack rhythm' is illustrated with two parts: 'ANT.' (antecedent) and 'CONS.' (consequent). The antecedent part shows a dotted eighth note followed by a sixteenth note. The consequent part shows a dotted eighth note followed by a sixteenth note, with the final note marked with an 'x' to indicate its identical relation to the preceding attack.

troduces another factor of imbalance in an already very complicated passage. But the beta palindrome does establish the measure as a temporal unit. Furthermore, we have already seen how the last two beta attacks articulate the center of the gamma palindrome.

Example 7a graphically portrays a formal property essential to the effect of the passage. Each trapezoid projects a palindromic symmetry, and each contributes its own formal stability and balance. But the trapezoids overlap irregularly, and their interaction develops a larger formal imbalance—or, one might say, a dynamic kind of balance, something like that of a Calder mobile. This shifting balance is palpable in the formation of the musical unit as its constituent parts accrue through time. To the ear and mind of this author, the shifting balance and asynchrony create special rhythmic force, and motivate the drive toward some greater stability. Because this rhythmic and formal imbalance requires stabilization, it func-

the end of the measure.) But the uppermost right-hand beams suggest  $\frac{3}{4}$  against  $\frac{6}{8}$ , and this is supported by the lower left-hand beams in the second part of the measure.

gamma *consequent* dyads are also repeated, even though they belong to that palindrome alone; however, were they not, their connection to the gamma antecedent dyads would be seriously obscured.

<sup>25</sup>To be exactly at the center, the attack would have to be one thirtysecond earlier—a needless complication in an already difficult passage.

<sup>26</sup>Schoenberg's beaming in the music of Example 6 is interesting in this regard. In m. 18, beams *between* the staves actually suggest a  $\frac{12}{16}$  division of the bar. (This gives a very different meaning to the "syncopated" {C,D} near

tions here as does dissonance in tonal music; the requirement to resolve tonal dissonance—along with its vast and varied implications for the formation of phrases—has been replaced in this context by imbalance in the mosaic polyphony. The desired stability arrives with the next formal unit beginning on the downbeat of m. 20, but only after the shocking silence of the last eighth in m. 19 has heightened the tension even further.<sup>27</sup>

It should be added that two additional factors play into the formal characterization of the passage. Initially the gamma palindrome does not arise as an independent structure. Its antecedent entries are actually just adjacencies in the alpha and beta palindromes. In retrospect, the gamma consequent binds the alpha and beta palindromes, because it synthesizes these adjacencies into a new element. Also, the last two dyad entries in m. 19 have not yet been placed within the context of the palindrome network. Those two final entries, on dyads {G♭, A♭} and {E, B♭}, sound respectively in the lowest and highest registers of the passage. They extend the expanding registral and contour gestures, and also produce row completion and aggregate completion. Of course, the Prelude is not yet over, and complete stability would be dubious. But some closure is certainly created by the extreme gestural climax. This formal completion is characterized by the lingering interaction of balance and imbalance so palpable in the last silent eighth of m. 19. The last two entries reinforce this sense of uncertain balance, because they continue the contrary motion of the gamma consequent and apparently extend it, even though they are not properly part of it.

A number of interesting rhythmic and registral symmetries in this passage deserve further investigation. Example 8a suggests how the rhythms of the {C, D} and {G♭, A♭} strata are

Example 8a. Rhythmic rotations on dyads {C, D} and {G♭, A♭}

The diagram illustrates rhythmic rotations on two dyads, {C, D} and {G♭, A♭}, across measures 18 and 19. The top part shows the {C, D} dyad, with rhythmic patterns in measures 18 and 19. The bottom part shows the {G♭, A♭} dyad, with rhythmic patterns in measures 18 and 19. Arrows indicate the rotation of rhythms between the two dyads. An asterisk (\*) is placed under the final eighth note of the {G♭, A♭} stratum in measure 19, indicating a slight departure from exact rotation.

very nearly rhythmic rotations of one another; an asterisk marks the one slight departure from exact rotation. Example 8b indicates that the {B, E♭} and {F, A} strata are similarly related.<sup>28</sup> To reflect these relationships, Figure 6 shows a new mosaic-isomorphism with order-number mosaic  $W_4$  and the associated pitch-class mosaic  $M_4$ , in which the pitch classes {G♭, A♭, C, D} are all grouped together in order positions {4, 6, 7, 9}, in the spirit of Example 8a, and the pitch-classes {F, A, B, E♭} are collected together in order positions {1, 5, 8, 10}, in the spirit of Example 8b.<sup>29</sup> By grouping together the rhythmically rotated dyads,  $W_4$  weakens mosaic  $W_3$  somewhat, so that it applies to all four rows “simultaneously,” and thus unifies the entire climax in a new way.

<sup>28</sup>The “slices” which segment the rotated rhythms are either one sixteenth before the barline, or on the barline. Those metric locations coincide, respectively, with consistent placement of order-number 4 dyads, or with the placement of the {G, D♭} dyad of order-numbers {2, 3}. This fact supports a number of ideas suggested earlier.

<sup>29</sup>This order-number mosaic is also discussed by Mead in “Some Implications,” 109.

<sup>27</sup>Readers may consult a score to see that the music of mm. 20–21 is very much in  $\frac{3}{4}$ , even though the meter has not been changed. This detail fits nicely with earlier remarks about the  $\frac{3}{4}$  tendencies of the beta rhythm in m. 18.

Example 8b. Rhythmic rotations on dyads {B,E♭} and {F,A}

Example 8b consists of four musical staves arranged in a 2x2 grid. The top-left staff is labeled {B, E♭} and shows a sequence of notes: a quarter note B, a quarter note E♭, a quarter note G, a quarter note D, a quarter note C, a quarter note F, a quarter note A, and a quarter note B. The top-right staff is labeled {F, A} and shows a sequence of notes: a quarter note F, a quarter note A, a quarter note G, a quarter note D, a quarter note C, a quarter note B, a quarter note E, and a quarter note F. The bottom-left staff is labeled {B, E♭} and shows a sequence of notes: a quarter note B, a quarter note E♭, a quarter note G, a quarter note D, a quarter note C, a quarter note F, a quarter note A, and a quarter note B. The bottom-right staff is labeled {F, A} and shows a sequence of notes: a quarter note F, a quarter note A, a quarter note G, a quarter note D, a quarter note C, a quarter note B, a quarter note E, and a quarter note F. Arrows indicate that the top-left staff is rotated to the bottom-right position, and the top-right staff is rotated to the bottom-left position. The bottom-left and bottom-right staves have an asterisk (\*) at the end.

SETLIST(M4) = (06)<sup>2</sup>(0268)<sup>2</sup>. Because each (0268) set can be derived (by interval “multiplication”) as either 06 × 02 or 06 × 04, M4 suggests greater harmonic stress on interval class 06 than does M3.<sup>30</sup> It is therefore not by chance that the rhythmically rotated dyads in Examples 8a and 8b are also tritone-related.

*W4* and *M4* are not only associated with rhythmic rotations; they are also reflected by registral symmetries. Example 9a shows that in m. 18 the pitch classes {C,D,G♭,A♭} are registally symmetric about D♭5, and also indicates that the pitch classes {C♭,E♭} join this symmetry in m. 18. Example 9b illustrates a similar feature in m. 19, where the pitch classes {C,D,G♭,A♭} are again registally symmetric, about G3; now the pitch classes {F,A} join in the symmetry. Moreover, the “right-hand” tetrachord of Example 9b occurs with identical intervallic spacing one octave higher in Example 9a; and the “left-hand” tetrachord of Example 9b sounds two octaves higher in Example 9a.

<sup>30</sup>Richard Cohn develops the idea of “multiplication,” which he calls “transpositional combination,” in “Inversional Symmetry and Transpositional Combination in Bartók,” *Music Theory Spectrum* 10 (1988): 19–42.

Figure 6. Mosaics *W4* and *M4* on all four principal rows “simultaneously”

Figure 6 shows a grid of pitch classes for four rows (P0, I6, P6, I0) across 12 columns (0-11). The rows are: P0: E, F, G, D♭, G♭, E♭, A♭, D, B, C, A, B♭; I6: B♭, A, G, D♭, A♭, B, G♭, C, E♭, D, F, E; P6: B♭, B, D♭, G, C, A, D, A♭, F, G♭, E♭, E; I0: E, E♭, D♭, G, D, F, C, G♭, A, A♭, C♭, B♭. The grid is divided into four 3x3 blocks by vertical lines at columns 3 and 6, and horizontal lines between rows P0/I6 and P6/I0. The blocks contain the following pitch classes: Block 1 (columns 0-2, rows P0-I0): E, F, G, B♭, B, D♭, E, E♭, D♭; Block 2 (columns 3-5, rows P0-I0): D♭, G, A♭, A, D, A♭, C, D, F; Block 3 (columns 6-8, rows P0-I0): G♭, E♭, B, C, F, G♭, A, A♭, C♭; Block 4 (columns 9-11, rows P0-I0): A, B♭, E, E, E♭, E, C♭, B♭.

$$W4 = \{\{0,11\}, \{2,3\}, \{4,6,7,9\}, \{1,5,8,10\}\}$$

$$M4 = \{\{E,B^\flat\}, \{G,D^\flat\}, \{G^\flat,A^\flat,C,D\}, \{F,A,E^\flat,B\}\}$$

$$\text{SETLIST}(M4) = (06)^2(0268)^2$$

Overall, mosaic *W4* is associated with rhythmic rotations and with registral symmetries, while mosaic *W3* is associated with palindromes, which suggest temporal symmetries. Each mosaic functions with respect to different parameters. None of these symmetries is entirely stable, and none of them functions on the entire aggregate. They are weighted against one another and function over different timespans. Each symmetry has an impact on formal structure and character, and unifies constituents in the music. The symmetric formations each produce a measure of balance, but together they produce a mobile and dynamic imbalance, a polyphony of symmetries. In this passage the opposition of stability and instability, or of balance and imbalance, is the principal “issue” upon which the formal unit is focused. Perception of these symmetries and balances makes the character and qualities of the passage more tangible, for both the listener and performer.

\* \* \*

It is not entirely by chance that in each of the preceding analyses the predominant mosaic membersets have been dy-

Example 9a. Prelude, m. 18; registral symmetry of {C,D,G♭,A♭} and {C♭,E♭} about D♭5



Example 9b. Prelude, m. 19; registral symmetry of {C,D,G♭,A♭} and {F,A} about G3



ads. That is a feature quite characteristic of Schoenberg's twelve-tone practice.<sup>31</sup> Indeed, dyadic thinking characterizes Schoenberg's musical mind more generally. In his famous analysis of the Andante from Brahms's A-Minor String Quartet, Op. 51 No. 2, Schoenberg derives the entire melody from its opening motive, a diatonic step. He concatenates this dyad to build new motives which span larger intervals—filled in, or as leaps—but the dyad remains the fundamental unit.<sup>32</sup> In *Remaking the Past*, Joseph Straus critiques Schoenberg's analysis on the grounds that his motives do not always jibe with logical Schenkerian voice-leading formulae.<sup>33</sup> In Straus's terms—derived from those of critic Harold Bloom—Schoenberg “strongly misreads” Brahms by considering the melodic motives outside of their tonal context. Schoenberg's

<sup>31</sup>In several of the hexachordal works, such as the Fourth Quartet, Op. 37, *mosaic-trichords* are also prominent, and function analogously as fundamental formal subunits. Obviously, the additional relational and ordering properties of trichords imply some differences in formal construction. But mosaic dyads are also sometimes deployed in the Fourth Quartet, and they do dominate other later works, such as the String Trio, Op. 45. They are also employed at special moments in *Moses und Aron*.

<sup>32</sup>Schoenberg, “Brahms the Progressive,” in *Style and Idea*, ed. Leonard Stein (Berkeley and Los Angeles: University of California Press, 1975), 429–31.

<sup>33</sup>Joseph Straus, *Remaking the Past: Musical Modernism and the Influence of the Tonal Tradition* (Cambridge: Harvard University Press, 1990), 29–31.

misreading therefore demonstrates all the more his inclination to think dyadically; it presents as much an image of his own thought as it does an analysis of Brahms's thinking. Other Schoenberg analyses betray the same predisposition toward dyads and their variational elaboration.<sup>34</sup> While Schoenberg sometimes does employ mosaic-trichords and larger membersets, mosaic-dyads are especially convenient for a logical and cohesive discourse, because they offer the smallest available formal subunits with interesting transformational properties. (The single tone alone presents no relational content as an independent formal unit.) At the same time, because of its minimal content, the dyad is the most compact, maximally comprehensible formal building block. Our analyses have already illustrated some ways in which dyads are combined to build other (larger) substructures in the music.<sup>35</sup>

<sup>34</sup>Straus cites an analysis of Mozart's Piano Sonata, K. 331, where Schoenberg again works from a dyadic motive (*Ibid.*, 35–36). Walter Frisch also discusses the Brahms A-Minor Quartet analysis, as well as Schoenberg's equally dyadic analysis of the opening from Brahms's F-Major Cello Sonata, in *Brahms and the Principle of Developing Variation* (Berkeley and Los Angeles: University of California Press, 1984), 4–8.

<sup>35</sup>In all three analyses we have seen how pairs of dyads are combined to yield interesting tetrachordal structures in the music. In hexachordal works, mosaic-dyads will generally divide the combinatorial hexachord evenly as

The analyses presented here have illustrated how mosaic polyphony reveals interacting formal balances in Schoenberg's music. The balanced formations often do not span an entire passage, and are usually restricted to only a part of the aggregate. But Schoenberg was opposed to complete balance and straightforward symmetry. The following statement, written by Schoenberg in June 1923 (about two years after the composition of the Prelude, and shortly after completion of the entire Suite) is apposite.

Perfect regularity (*symmetry* and the like) is not suited to music. Rather, coherence is achieved through contrast (antiphony, countersubject, comes, secondary theme, dominant, etc.). At least, all developed forms will feature contrast. Petrified music, on the other hand, might be commensurate with perfect regularity.<sup>36</sup>

Here, Schoenberg's terminology appears to refer to tonal composition only; in the analyses presented above, similar notions governing his twelve-tone discourse are evident. These analyses reveal in Schoenberg's twelve-tone music how

several independently symmetric or balanced structures are heard in counterpoint with one another. This author suggests that it is this counterpoint, producing either a balanced or unbalanced whole, that lends Schoenberg's music its characteristic plasticity and drive.

#### ABSTRACT

Order-number mosaics and their associated pitch-class mosaics are applied to twelve-tone rows in Schoenberg's music, and the notion of *mosaic polyphony* is developed to study the rhythmic structures thus highlighted in a musical excerpt. The mosaic polyphony is then used as a basis for observations about the music's formal construction. Several analyses, all drawn from the Prelude from the Suite for Piano, Op. 25, show how rhythmic, metrical, and registral features, sometimes involving powerful symmetries, affect phrase formation and cohesion, and give the music its special dynamic balance and characteristic fluidity.

---

well. Mosaic-trichords also divide the hexachord evenly, but will be at some odds with possible mosaic-dyads. The author has found several passages in the Fourth Quartet where mosaic-dyads and mosaic-trichords coexist in *polyphony* with one another. Other divisions of the row, such as the pentachords of the Third Quarter, Op. 30, represent a very different—and quite unique—stage in Schoenberg's twelve-tone development.

<sup>36</sup>This statement, translated by Leonard Stein, appeared in "Schoenberg: Five Statements," *Perspectives of New Music* 14, no. 1 (1975): 165.